

Krenz *Instrumentation*

M2i.20xx - 8 bit transient recorder up to 200 MS/s

- Up to 200 MS/s on 2 channels, 100 MS/s on 4 channels
- Simultaneously sampling on all channels
- Separate ADC and amplifier per channel
- 7 input ranges: ± 50 mV up to ± 5 V
- Up to 4 GSample on-board memory
- 64 MSample standard memory installed
- Window, pulse width, re-arm, OR/AND trigger
- Programmable input offset of $\pm 400\%$
- Synchronization of up to 16 cards per system and up to 271 cards with system sync
- ABA mode option: combination of data logger and fast digitizer on trigger
- Versatile software support for Windows and Linux



- | | |
|---|--|
| <ul style="list-style-type: none"> • 66 MHz 32 Bit PCI-X interface • 5V / 3.3V PCI compatible • 100% compatible to conventional PCI > V2.1 • Sustained streaming mode up to 225 MB/s | <ul style="list-style-type: none"> • 2,5 GBit x1 PCIe Interface • Works with x1/x4/x8/x16* PCIe slots • Software compatible to PCI • Sustained streaming mode up to 160 MB/s |
|---|--|

<u>Operating Systems</u> <ul style="list-style-type: none"> • Windows 2k, XP, Vista • Linux Kernel 2.4 + 2.6 • Both 32 and 64 bit 	<u>Recommended Software</u> <ul style="list-style-type: none"> • Visual Basic, Visual C++, Borland C++ Builder, GNU C++, Borland Delphi, VB.NET • SBench, SPviewIT 	<u>Drivers</u> <ul style="list-style-type: none"> • MATLAB • LabVIEW, LabWindows • DASY Lab • Agilent VEE
--	--	---

Model	1 channel	2 channels	4 channels
M2i.2020	50 MS/s	50 MS/s	
M2i.2021	50 MS/s	50 MS/s	50 MS/s
M2i.2030	200 MS/s	100 MS/s	
M2i.2031	200 MS/s	200 MS/s	100 MS/s

General Information

The cards of the M2i.20xx series are designed for the fast and high quality data acquisition. Each of the up to four input channels has its own A/D converter and its own programmable input amplifier. This allows to record signals on all channels with 8 bit resolution without any phase delay between them. The inputs can be selected to one of seven input ranges by software and can be programmed to compensate for an input offset of $\pm 400\%$ of the input range. The extremely large on-board memory allows long time recording even with highest sampling rates. All four cards of the M2i.20xx series may use the whole installed on-board memory completely for the currently activated number of channels. A FIFO mode is also integrated on the board. This allows the acquisition of data continuously for online processing in the PC or for data storage on hard disk.

*Some x16 PCIe slots are for the use of graphic cards only and can not be used for other cards.

Software Support

Windows drivers

The cards are delivered with drivers for Windows 2000, Windows XP, Windows XP64 and Windows Vista. Programming examples for Visual C/C++, Borland C++ Builder, LabWindows/CVI, Borland Delphi, Visual Basic and VB.NET are included.

Linux Drivers



All cards are delivered with full Linux support. Pre compiled kernel modules are included for the most common distributions like RedHat, Fedora, Suse or Debian. The Linux support includes SMP systems, 32 bit and 64 bit systems, versatile programming examples for Gnu C++ as well as the possibility to get the driver sources for own compilation.

SBench

A full licence of SBench the easy-to-use graphical operating software for the Spectrum cards is included in the delivery. The version 6 is running under Windows as well as under Linux (KDE and GNOME).

SPViewIT

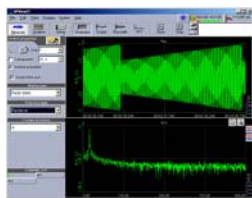

SPViewIT is the professional streaming software solution for the Spectrum PC instruments. The software is optimised for continuous data acquisition of large amounts of data. Key features of SPViewIT are different data displays, editable interface and a huge amount of export filters. A demo version comes with the

card.

Third-party products

A lot of third-party products are supported as an option. Choose between LabVIEW, MATLAB, DASYLab and Agilent VEE. All drivers come with examples and detailed documentation.

MI Software compatibility layer

To allow an easy change from MI cards to the new M2i cards for existing software a special software compatibility layer is delivered with the cards. This DLL converts MI calls to M2i calls and simulates a MI card in the software.

Hardware features and options

PCI/PCI-X



The M2i cards with PCI/PCI-X bus connector use 32 Bit and up to 66 MHz clock rate for data transfer. They are 100% compatible to Conventional PCI > V2.1. The universal interface allows the use in PCI slots with 5 V I/O and 3.3 V I/O voltages as well as in

PCI-X or PCI 64 slots. The maximum sustained data transfer rate is 225 MByte/s per bus segment.

PCI Express



The M2i cards with PCI Express use a x1 PCIe connector. They can be used in PCI Express x1/x4/x8/x16 slots, except special graphic card slots, and are 100% software compatible to Conventional PCI > V2.1. The maxi-

mum sustained data transfer rate is 160 MByte/s per slot.

Input Amplifier

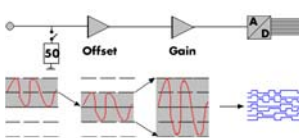

The analog inputs can be adapted to real world signals using a wide variety of settings that are individual for each channel. By using software commands the input termination can be changed

between 50 Ohm and 1 MOhm, one can select a matching input range and the signal offset can be compensated for.

Ring buffer mode

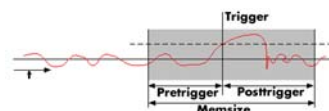

The ring buffer mode is the standard mode of all oscilloscope boards. Data is written in a ring memory of the board until a trigger event is

detected. After the event the posttrigger values are recorded. Because of this continuously recording into a ring buffer there are also samples prior to the trigger event visible: Pretrigger = Memsiz - Posttrigger.

FIFO mode

The FIFO mode is designed for continuous data transfer between measurement board and PC memory (up to 225 MB/s on a PCI-X slot and up to 115 MB/s on a PCI slot) or hard disk. The control of the data stream is done automatically by the driver on interrupt request. The complete installed on-board memory is used for buffer data, making the continuous streaming extremely reliable.

Channel trigger

The data acquisition boards offer a wide variety of trigger modes. Besides the standard signal checking for level and edge as known from oscilloscopes it's also possible to define a window trigger. All trigger modes can be combined with the pulsewidth trigger. This makes it possible to trigger on signal errors like too long or too short pulses. In addition to this a re-arming mode (for accurate trigger recognition on noisy signals) the AND/OR conjunction of different trigger events is possible. As a unique feature it is possible to use deactivated channels as trigger sources.

External trigger I/O

All boards can be triggered using an external TTL signal. It's possible to use positive or negative edge also in combination with a programmable pulse width. An internally recognised trigger event can - when activated by software - be routed to the trigger connector to start external instruments.

Pulse width

Defines the minimum or maximum width that a trigger pulse must have to generate a trigger event. Pulse width can be combined with channel trigger, pattern trigger and external trigger.

Multiple Recording

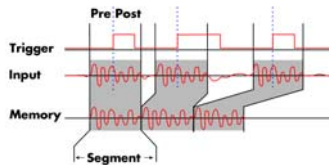

The Multiple Recording option allows the recording of several trigger events with an extremely short re-arming time. The hardware doesn't need to be restarted in between. The on-board memory is divided in several segments of the same size. Each of them is filled with data if a trigger event occurs. Pre- and posttrigger of the segments can be programmed. The number of acquired segments is only limited by the used memory and is unlimited when using FIFO mode.

Gated Sampling

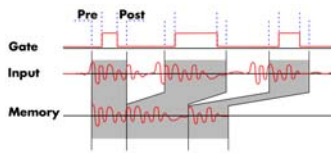

The Gated Sampling option allows data recording controlled by an external gate signal. Data is only recorded if the gate signal has a programmed level. In addition a pre-area before start

of the gate signal as well as a post area after end of the gate signal can be acquired. The number of gate segments is only limited by the used memory and is unlimited when using FIFO mode.

Timestamp

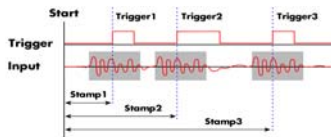

The timestamp option writes the time positions of the trigger events in an extra memory. The timestamps are relative to the start of recording, a defined zero time, externally synchronised to a radio clock, or a GPS receiver. With this option acquisitions of systems on different locations can be set in a precise time relation.

With this option acquisitions of systems on different locations can be set in a precise time relation.

ABA mode

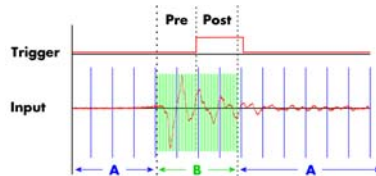

The optional ABA mode combines slow continuous data recording with fast acquisition on trigger events. The ABA mode works like a slow data logger combined with a fast digitizer. The

exact position of the trigger events is stored as timestamps in an extra memory.

External clock I/O

Using a dedicated connector a sampling clock can be fed in from an external system. It's also possible to output the internally used sampling clock to synchronise external equipment to this clock.

Reference clock

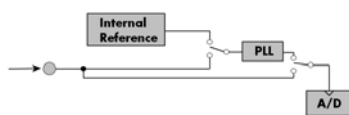

The option to use a precise external reference clock (normally 10 MHz) is necessary to synchronise the board for high-quality

measurements with external equipment (like a signal source). It's also possible to enhance the quality of the sampling clock in this way. The driver automatically generates the requested sampling clock from the fed in reference clock.

Star-Hub



The star-hub is an additional module allowing the phase stable synchronisation of up to 16 boards in one system. Independent of the number of boards there is no phase delay between all channels. The star-hub distributes trigger and

clock information between all boards. As a result all connected boards are running with the same clock and the same trigger. All trigger sources can be combined with OR/AND allowing all channels of all cards to be trigger source at the same time. The star-hub is available as 5 card and 16 card version. The 5 card version doesn't need an extra slot.

271 synchronous cards with the System Star-Hub

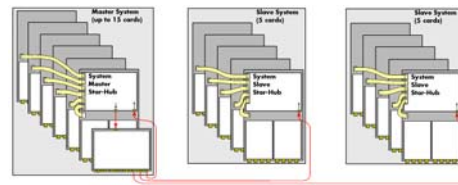

With the help of multiple system star-hubs it is possible to link up to 17 system phase synchronous

with each other. Each system can then contain up to 16 cards (master only 15). In total 271 cards can be used fully synchronously in a bunch of systems. One master system distributes clock and trigger signal to all connected slave systems.

BaseXIO (enhanced trigger)



The BaseXIO option offers 8 asynchronous digital I/O lines on the base card. The direction can be selected by software in groups of four. Two of these lines can also be used as additional external trigger

sources. This allows the building of complex trigger conjunctions with external gated triggers as well as AND/OR conjunction of multiple external trigger sources like, for example, the picture and row synchronisation of video signals. In addition one of the I/O lines can be used as reference clock for the Timestamp counter.

Technical Data

Analog Inputs

Resolution	8 bit
Differential non linearity (DNL)	≤ 0.5 LSB (ADC)
Integral non linearity (INL)	≤ 0.5 LSB (ADC)
Offset error	can be calibrated by user
Gain error	< 2% of current value
Programmable input offset	±400% of current input range
Crosstalk 1 MHz signal, 50 Ohm term	< -62 dB between any adjacent channels
Input signal with 50 Ohm termination	max 5 V rms
Analog Input impedance	50 Ohm / 1 MOhm 25 pF
Over voltage protection (range ≤ ±0.5 V)	±5 V
Over voltage protection (range > ±0.5 V)	±50 V
Connector (analog and trigger/clock)	3 mm SMB male

Trigger

Multi, Gate: re-arming time	<4 Samples
Max Pretrigger at Multi, Gate, FIFO	16352 Samples as sum of all active channels
Trigger accuracy (≤100 MS/s)	1 Sample (internal or external trigger mode)
Trigger accuracy (>100 MS/s)	2 Samples (internal or external trigger mode)
Channel trigger resolution	8 bit
Trigger output delay	One positive edge after internal trigger event
External trigger type	3.3V LVTTTL compatible (5V tolerant)
External trigger input	Low ≤ 0.8 V, High ≥ 2.0 V, ≥ 2 clock periods
External trigger maximum voltage	-0.5 V up to +5.7 V (internally clamped to 5.0V, 100 mA max. clamping current)
External trigger output levels	Low ≤ 0.4 V, High ≥ 2.4 V, TTL compatible
External trigger output drive strength	Capable of driving 50 ohm load

Software programmable parameters

Input Ranges	±50 mV, ±100 mV, ±200 mV, ±500 mV, ±1 V, ±2 V, ±5 V
Input impedance	50 Ohm / 1 MOhm
Input Offset	±400% of input range in steps of 1%
Clock mode	Int. PLL, int. quartz, ext. clock, ext. divided, ext. reference clock, sync
Clock impedance	50 Ohm / high impedance (> 4kOhm)
Trigger impedance	50 Ohm / high impedance (> 4kOhm)
Trigger mode	Channel, Extern, SW, Auto, Window, Pulse, Re-Arm, Or/And, Delay
Trigger level	8 bit resolution: 1/256 to 255/256 of input range
Trigger edge	Rising edge, falling edge or both edges
Trigger pulse width	0 to [64k - 1] samples in steps of 1 sample
Trigger delay	0 to [64k - 1] samples in steps of 1 sample
Memory depth	8 up to [installed memory / number of active channels] in steps of 8
Posttrigger	4 up to [8G - 4] samples in steps of 4
Multiple Recording segment size	8 up to [installed memory / 2 / active channels] in steps of 4
Multi / Gated pretrigger	0 up to [16k samples / number of active channels - 32]
ABA clock divider	1 up to [64k - 1] in steps of 1
Synchronization clock divider	2 up to [8k - 2] in steps of 2
Channel selection	Any 1, 2 or 4 channels (see manual for clock limits on the selections)

Clock

Internal clock range (PLL mode)	1 kS/s to max (see table below)
Internal clock accuracy	20 ppm
Internal clock: max. jitter in PLL mode	TBD
Internal clock: max. jitter in quartz mode	TBD
Internal clock setup granularity	≤1% of range (100M, 10M, 1M, 100k,...)
Internal clock setup granularity example	range 1M to 10M: stepsize ≤ 100k
Reference clock: external clock range	≥ 1.0 MHz and ≤ 125.0 MHz
External clock range	1 MS/s to max (see table below)
External clock delay to internal clock	5.4 ns
External clock type	3.3V LVTTTL compatible
External clock input	Low ≤ 0.8 V, High ≥ 2.0 V, duty 45% - 55%
External clock maximum voltage	-0.5 V up to +3.8 V (internally clamped to 3.3V, 100 mA max. clamping current)
External clock output levels	Low ≤ 0.4 V, High ≥ 2.4 V, TTL compatible
External clock output drive strength	Capable of driving 50 ohm load

Environmental and Physical details

Dimension (PCB only)	312 mm x 107 mm (full PCI length)
Width (Standard or star-hub 5)	1 full size slot
Width (star-hub 16)	2 full size slots
Weight (depending on options/channels)	290g (2 ch) up to 420g (4 ch + sh)
Warm up time	10 minutes
Operating temperature	0°C - 50°C
Storage temperature	-10°C - 70°C
Humidity	10% to 90%

PCI / PCI-X specific details

PCI / PCI-X bus slot type	32 bit 33/66 MHz
PCI / PCI-X bus slot compatibility	32/64 bit, 33-133 MHz, 3,3 V and 5 V I/O

PCI EXPRESS specific details

PCIe slot type	x1
PCIe slot compatibility	x1/x4/x8/x16*

*Some x16 PCIe slots are for graphic cards only and can not be used for other cards.

Power consumption (max speed)

	PCI / PCI-X		PCI EXPRESS	
	3,3 V	5 V	3,3 V	12V
M2i.20x0 (64 MS memory)	2,2 A	0,5 A	0,4 A	1,0
M2i.20x1 (64 MS memory)	2,8 A	0,8 A	0,4 A	1,2
M2i.2031 (4 GS memory), max power	3,9 A	0,8 A	0,4 A	2,0

Max channels / Star-Hub Option

	SH5	SH16	SSH55	SSH516
M2i.2020/2030	10	32	170	542
M2i.2021/2031	20	64	340	1084

BaseXIO (Option)

BaseXIO Connector (extra bracket)	8 x SMB (8 x MMCX internal)
BaseXIO input	TTL compatible: Low ≤ 0.8 V, High ≥ 2.0 V
BaseXIO input maximum voltage	-0.5 V up to +5.5 V
BaseXIO output levels	TTL compatible: Low ≤ 0.4 V, High ≥ 2.4 V
BaseXIO output drive strength	32 mA maximum current

Certifications and Compliances

EMC Immunity	Compliant with CE Mark
EMC Emission	Compliant with CE Mark

Dynamic Parameters

	M2i.2020		M2i.2021		M2i.2030		M2i.2031	
max internal clock	50 MS/s		50 MS/s		200 MS/s		200 MS/s	
max external clock	50 MS/s		50 MS/s		100 MS/s		100 MS/s	
-3 dB bandwidth	DC to 25 MHz		DC to 25 MHz		DC to 90 MHz		DC to 90 MHz	
Zero noise level (≤ ±100 mV)	≤ 0,6 LSB		≤ 0,9 LSB		≤ 1,5 LSB		≤ 2,0 LSB	
Zero noise level (> ±100 mV)	≤ 0,6 LSB		≤ 0,7 LSB		≤ 1,3 LSB		≤ 1,5 LSB	
Test - sampling rate	50 MS/s		50 MS/s		100 MS/s		100 MS/s	
Test signal frequency	1 MHz	4 MHz	1 MHz	4 MHz	1 MHz	9 MHz	1 MHz	9 MHz
SNR (typ)	47.5 dB	47.5 dB	46.8 dB	46.5 dB	45.3 dB	45.0 dB	45.0 dB	44.5 dB
THD (typ)	-56.0 dB	-55.5 dB	-56.0 dB	-55.5 dB	-51.5 dB	-49.5 dB	-49.5 dB	-49.5 dB
SFDR (typ), excl. harm.	61.3 dB	61.0 dB	60.3 dB	60.1 dB	59.0 dB	57.0 dB	59.0 dB	57.0 dB
ENOB (based on SNR)	7.6 bit	7.6 bit	7.5 bit	7.4 bit	7.2 bit	7.2 bit	7.2 bit	7.2 bit
ENOB (based on SINAD)	7.5 bit	7.5 bit	7.4 bit	7.3 bit	7.1 bit	7.0 bit	7.1 bit	7.0 bit

Dynamic parameters are measured at ± 1 V input range (if no other range is stated) and 50 Ohm termination with the samplerate specified in the table. Measured parameters are aver-

aged 20 times to get typical values. Test signal is a pure sine wave of the specified frequency with > 99% amplitude. SNR and RMS noise parameters may differ depending on the quality of the used PC. SNR = Signal to Noise Ratio, THD = Total Harmonic Distortion, SFDR = Spurious Free Dynamic Range, SINAD = Signal Noise and Distortion, ENOB = Effective Number of Bits. For a detailed description please see application note 002.

Hardware block diagram

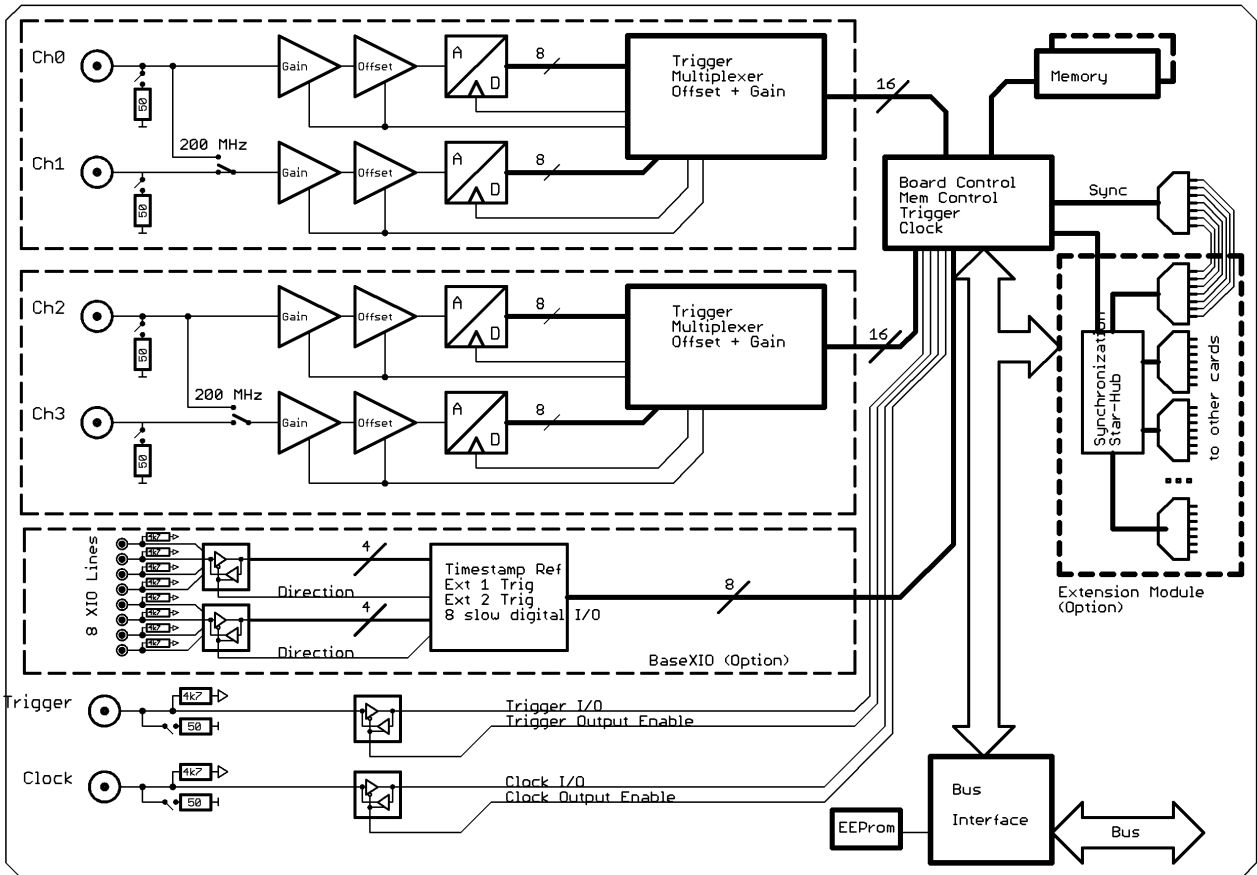

Order Informations

PCI/PCI-X

Order no.	Standard mem	1 channel	2 channels	4 channels
M2i.2020	64 MByte	50 MS/s	50 MS/s	
M2i.2021	64 MByte	50 MS/s	50 MS/s	50 MS/s
M2i.2030	64 MByte	200 MS/s	100 MS/s	
M2i.2031	64 MByte	200 MS/s	200 MS/s	100 MS/s

PCI Express

Order no.	Standard mem	1 channel	2 channels	4 channels
M2i.2020-exp	64 MByte	50 MS/s	50 MS/s	
M2i.2021-exp	64 MByte	50 MS/s	50 MS/s	50 MS/s
M2i.2030-exp	64 MByte	200 MS/s	100 MS/s	
M2i.2031-exp	64 MByte	200 MS/s	200 MS/s	100 MS/s

Memory

Order no.	Option
M2i.xxxx-128MB	Memory upgrade to 128 MB of total memory
M2i.xxxx-256MB	Memory upgrade to 256 MB of total memory
M2i.xxxx-512MB	Memory upgrade to 512 MB of total memory
M2i.xxxx-1GB	Memory upgrade to 1 GB of total memory
M2i.xxxx-2GB	Memory upgrade to 2 GB of total memory
M2i.xxxx-4GB	Memory upgrade to 4 GB of total memory

Options

Order no.	Option
M2i.xxxx-mr	Option Multiple Recording
M2i.xxxx-mgt	Option pack including Multiple Recording, Gated Sampling, Timestamp
M2i.xxxx-mgtab	Option pack including Multiple Recording, Gated Sampling, Timestamp, ABA mode
M2i.xxxx-SH5 (1)	Synchronization Star-Hub for up to 5 cards, only 1 slot width
M2i.xxxx-SH16 (1)	Synchronization Star-Hub for up to 16 cards
M2i.xxxx-SSHM (1)	System-Star-Hub Master for up to 15 cards in the system and up to 17 systems, sync cables included
M2i.xxxx-SSHS5 (1)	System-Star-Hub Slave for up to 5 cards in one system, all sync cables included
M2i.xxxx-SSHS16 (1)	System-Star-Hub Slave for up to 16 cards in one system, all sync cables included
M2i.xxxx-bxio	Option BaseXIO: 8 digital I/O lines usable as asynchronous I/O, timestamp ref-clock and additional external trigger lines, additional bracket with 8 SMB connectors
M2i-upgrade	Upgrade for M2i.xxxx: later installation of option -dig or -bxio

Cables

Order no.	Option
Cab-3f-9m-80	Adapter cable SMB female to BNC male, 80 cm
Cab-3f-9f-80	Adapter cable SMB female to BNC female, 80 cm
Cab-3f-3f-80	Adapter cable SMB female to SMB female, 80 cm
Cab-3f-9m-200	Adapter cable SMB female to BNC male, 200 cm
Cab-3f-9f-200	Adapter cable SMB female to BNC female, 200 cm
Cab-3f-3f-200	Adapter cable SMB female to SMB female, 200 cm
Cab-3f-9f-5	Adapter cable SMB female to BNC female, 5 cm (short cable especially for oscilloscope probes)

Drivers

Order no.	Option
M2i.xxxx-ml	MATLAB driver for all M2i cards
M2i.20xx-lv	LabVIEW driver for all M2i.20xx cards
M2i.20xx-dl	DASLab driver for all M2i.20xx cards
M2i.20xx-vee	Agilent VEE driver for all M2i.20xx cards

(1) : Just one of the options can be installed on a card at a time.

technical changes and printing errors possible